

Door L-VAT with double acting pneumatic actuator

Series 075
50 × 336 mm (1.97" × 13.23")

This manual is valid for the following product ordering numbers:
075..- -

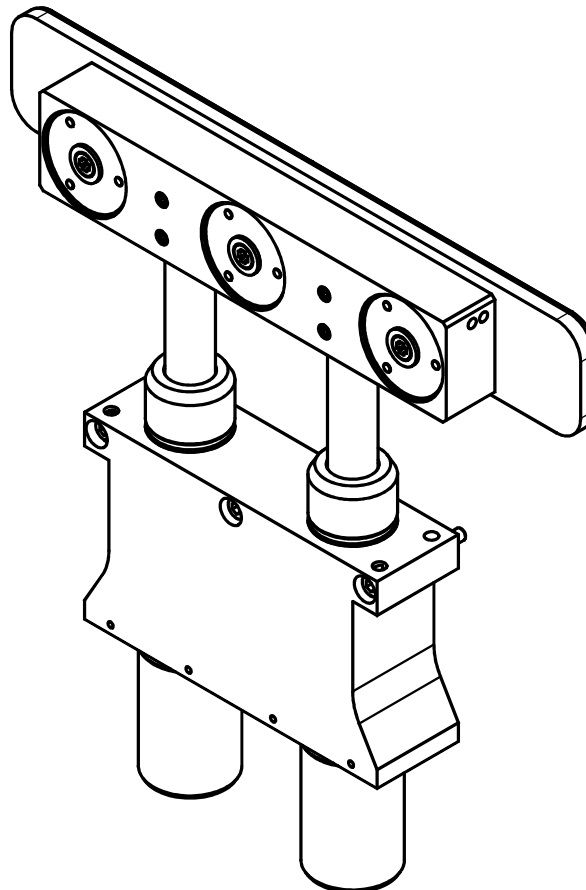

Sample picture

Imprint

Manufacturer VAT Vakuumventile AG, CH-9469 Haag, Switzerland

Website: www.vatvalve.com
Phone: +41 81 771 61 61
Fax: +41 81 771 48 30
Email: CH@vatvalve.com

Publisher VAT Vakuumventile AG, CH-9469 Haag, Switzerland

Editor VAT Vakuumventile AG, CH-9469 Haag, Switzerland

Print VAT Vakuumventile AG, CH-9469 Haag, Switzerland

Copyright © VAT Vakuumventile AG 2014

No part of these instructions may be reproduced in any way (photocopies, microfilms or any other reproduction processes) nor may it be manipulated with electronic systems, duplicated or distributed without written permission from VAT. Offenders are liable to pay damages.

The original VAT firmware and updated state of the art versions of the VAT firmware are intended for use with VAT products. The VAT firmware contains a limited, time unlimited user license. The VAT firmware may not be used for purposes other than those intended nor is it permitted to make copies of the VAT firmware. In particular, it is strictly forbidden to give copies of the VAT firmware to other people.

The use of trade names, brand names, trademarks, etc. in these Instructions does not entitle third parties to consider these names to be unprotected and to use them freely. This is in accordance with the meaning of the laws and acts covering brand names and trademarks.

Contents

1	Description of product.....	5
1.1	Identification of product.....	5
1.2	Use of product.....	5
1.3	Used abbreviations.....	5
1.4	Related documents.....	5
1.5	Important information.....	5
1.6	Technical data.....	5
2	Safety	6
2.1	Compulsory reading material.....	6
2.2	Danger levels	6
2.3	Personnel qualifications.....	7
2.4	Safety labels.....	7
3	Design and Function.....	8
3.1	Design.....	8
3.2	Function	9
4	Installation	10
4.1	Unpacking	10
4.2	Installation into the system.....	11
4.3	Compressed air connection	12
4.4	Electrical connection.....	12
4.5	Initial operation.....	13
5	Operation	14
5.1	Normal operation.....	15
5.2	Operation under increased temperature.....	15
5.3	Behavior in case of air pressure drop.....	15
5.4	Behavior in case of power failure	15
5.5	Trouble shooting.....	16
6	Maintenance	17
6.1	Maintenance intervals.....	17
6.2	Required tools	17
6.3	Replacement of actuator pneumatic seals.....	18
6.4	Replacement of gate	20
7	Repairs	22
8	Dismounting and Storage.....	23
8.1	Dismounting	24
8.2	Storage	24
9	Packaging and Transport	25
9.1	Packaging	26
9.2	Transport.....	26

10	Disposal.....	27
11	Spare parts.....	28

1 Description of product

1.1 Identification of product

The fabrication number and order number are fixed on the product directly or by means of an identification plate.

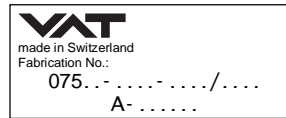

← Fabrication number

← Order number

1.2 Use of product

Use product for clean and dry vacuum applications only. Other applications are only allowed with the written permission of VAT.

1.3 Used abbreviations

Abbreviation	Description
ATM	Atmospheric
CDA	Compressed dry air

Table 1-1

1.4 Related documents

- Product data sheet
- Dimensional drawing

1.5 Important information



This symbol points to a very important statement that requires particular attention.

Example:



VAT disclaims any liability for damages resulting from inappropriate packaging.

1.6 Technical data

See product data sheet and dimensional drawing.

2 Safety

2.1 Compulsory reading material

Read this chapter prior to performing any work with or on the product. It contains important information that is significant for your own personal safety. This chapter must have been read and understood by all persons who perform any kind of work with or on the product during any stage of its serviceable life.

	NOTICE
	<p>Lack of knowledge Failing to read this manual may result in property damage. Firstly, read manual.</p>



These Installation, Operating & Maintenance Instructions are an integral part of a comprehensive documentation belonging to a complete technical system. They must be stored together with the other documentation and accessible for anybody who is authorized to work with the system at any time.

2.2 Danger levels



	⚠ DANGER
	<p>High risk Indicates a hazardous situation which, if not avoided, will result in death or serious injury.</p>

	⚠ WARNING
	<p>Medium risk Indicates a hazardous situation which, if not avoided, could result in death or serious injury.</p>

	⚠ CAUTION
	<p>Low risk Indicates a hazardous situation which, if not avoided, may result in minor or moderate injury.</p>

	NOTICE
	<p>Command Indicates a hazardous situation which, if not avoided, may result in property damage.</p>

2.3 Personnel qualifications

	 WARNING
	<p>Unqualified personnel Inappropriate handling may cause serious injury or property damage. Only qualified personnel are allowed to carry out the described work.</p>

2.4 Safety labels

Label	Part No.	Location on product
	T-9001-155	Outer side of both horizontal actuators

Table 2-1

3 Design and Function

3.1 Design

Door type V

Actuator body mounted to bottom of chamber

Door type U

Actuator body mounted to chamber wall

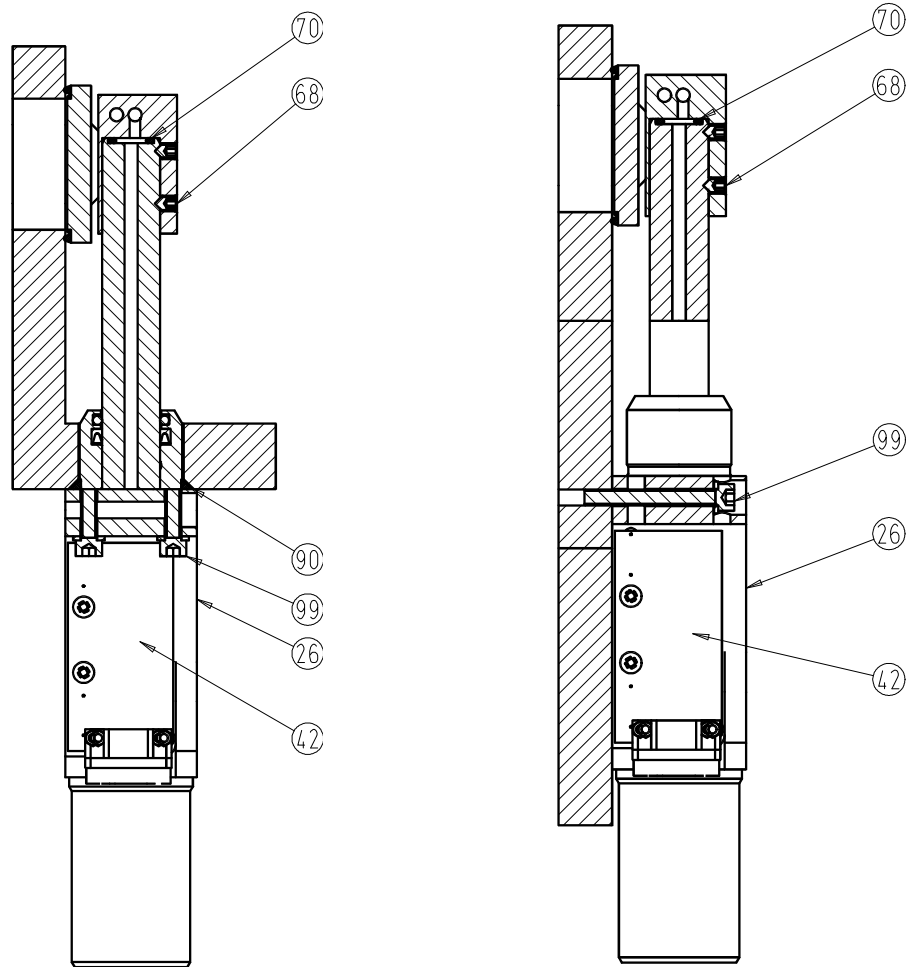

Figure 3-1

26	Actuator body	70	O-ring
42	Position indicator	90	O-ring
68	Set screw	99	Screw

3.2 Function

The 075 ATM door consists of two vertical pneumatic cylinders, one pneumatic box and three horizontal actuators. The vertical cylinders move from open to closed position in the vertical direction. The horizontal actuators move the gate from the open position to the closed position in horizontal direction. The gate moves in a so called L-movement.

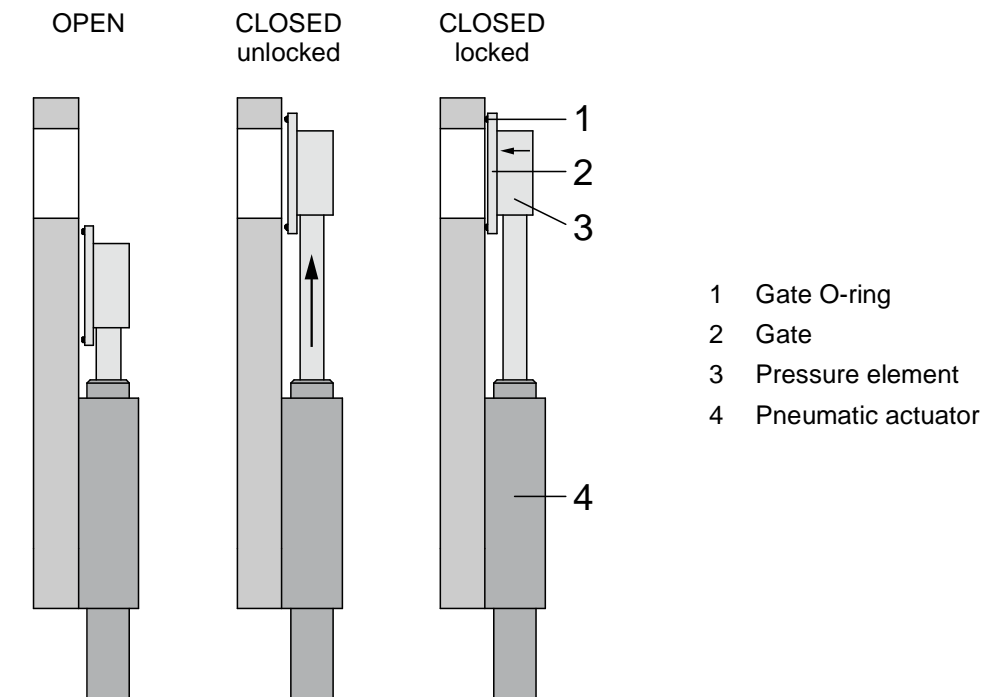





Figure 3-2

4 Installation

	 WARNING
	<p>Unqualified personnel Inappropriate handling may cause serious injury or property damage. Only qualified personnel are allowed to carry out the described work.</p>

	NOTICE
	<p>Insufficient stability Product will get damaged if it is not stabilized. Assistant staff required to lift and stabilize the product during mounting.</p>

4.1 Unpacking



- Make sure that the supplied product is in accordance with your order.
- Inspect the quality of the supplied product visually. If it does not meet your requirements, please contact VAT immediately.
- Store the original packaging material. It may be useful if the product must be returned to VAT.

1. Cut plastic straps and open the transport box.



Remove plastic bag in a cleanroom only.

2. Open the plastic bag to unpack gate and actuator.

	NOTICE
	<p>Sensitive product Product will get damaged if not handled carefully. Handle product with care: Do not touch solid objects when lifting the product and place it down slowly and gently.</p>

3. Place products on a clean surface.

4.2 Installation into the system

	⚠ WARNING
	<p>Hazardous components</p> <p>Parts, loaded springs, air cushions etc. may move or release a movement and cause serious injury.</p> <p>Do not connect or supply electrical power and compressed air before the product is completely mounted in the system.</p>

	NOTICE
	<p>Contamination</p> <p>Product may get contaminated.</p> <p>Always wear cleanroom gloves when handling the product.</p>

	NOTICE
	<p>Insufficient stability</p> <p>Product may get damaged when actuated at this stage.</p> <p>Do not operate before product is installed completely into the vacuum system.</p>

	NOTICE
	<p>Wrong tightening torque</p> <p>Door and screws may get damaged.</p> <p>Use tightening torque according to the size of the screws.</p>



- Make sure that sealing surfaces of the door and the chamber are undamaged. Mount door to a clean system only.
- Make sure that dimensions and tolerances specified on the dimensional drawing are strictly met.

1. Mount actuator to the chamber, use screws (99) M6x50 mm; see «Figure 3-1» on page 8.



Quantity of screws depends on mounting position. For U-Type, 3 screws are required, for V-Type, 4 screws are required.

4.3 Compressed air connection

	WARNING
	<p>Product in open position Risk of injury when compressed air is connected to the product. Connect compressed air only when:</p> <ul style="list-style-type: none"> – product is installed to the vacuum system – moving parts cannot be touched

Use clean, dry or slightly oiled air only.

Admissible air pressure range, see product data sheet.

1. Connect compressed air according to the product data sheet and dimensional drawing.

4.4 Electrical connection

	WARNING
	<p>Product in open position Risk of injury when product is put into operation. Keep human body parts away from movable parts.</p>

	NOTICE
	<p>Wrong voltage Electrical components may get damaged. Supply electrical components with the correct voltage.</p>

1. Connect position indicator according to the product data sheet and dimensional drawing.

4.5 Initial operation

	⚠ WARNING
	Movable parts Human body parts may get jammed and severely injured. Keep human body parts away from movable parts.



L-movement requires initializing of compressed air system. The door command must be set **to open at first**. This will pressurize the pneumatic system and ensure the proper L-movement during the following closing cycles.

1. Open the door.
2. Close the door.

5 Operation

	⚠ WARNING
	<p>Unqualified personnel Inappropriate handling may cause serious injury or property damage. Only qualified personnel are allowed to carry out the described work.</p>

	⚠ WARNING
	<p>Movable parts Human body parts may get jammed and severely injured. Do not operate before product is installed completely into the vacuum system. Until actuation of the door keep human body parts away from movable parts.</p>



During operation of the ATM door the pneumatic cylinders move the gate. There are small gaps with danger of injury, see «Figure 5-1». Take appropriate measures to avoid possible human injury. Do not insert body parts through door opening during operation of door.

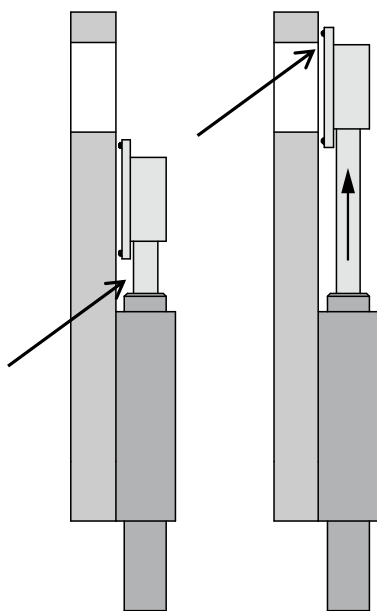

Figure 5-1

Small gaps

5.1 Normal operation

The door opens and closes pneumatically.

5.2 Operation under increased temperature

Maximum allowed temperature, see product data sheet.

5.3 Behavior in case of air pressure drop

See product data sheet.



L-movement requires initializing of compressed air system. The door command must be set **to open at first**. This will pressurize the pneumatic system and ensure the proper L-movement during the following closing cycles.



Proper function of internal nonreturn valve depends on speed of air pressure drop. Slow pressure drop in air supply will not trigger the nonreturn valve, therefore the position of the door will be undefined at loss of compressed air pressure.

1. Open the door.
2. Close the door.

5.4 Behavior in case of power failure

Depending on customer's installation.

5.5 Trouble shooting

Failure	Check	Action	See
Leak at gate	Check seals and sealing surfaces	Clean sealing surfaces	Product data sheet
	Damage of gate	Replace gate	«6.4 Replacement of gate»
	Seal compression of gate	Check compressed air	Product data sheet and dimensional drawing
Door cannot be operated	Connection of air lines	Check compressed air lines	Product data sheet and dimensional drawing
	Connection of power	Check power lines	Product data sheet and dimensional drawing
Gate slides at chamber wall	Installation and initial command	<ol style="list-style-type: none"> 1. Move door to open position 2. Attach door to chamber 3. Connect air to “OPEN”-port” only. 4. Block port “P” so no air can leave this port 5. Connect air tubing to “P-port” and apply CDA to this port 6. Move door to “CLOSED”-position 	Product data sheet and dimensional drawing
	Compressed air	Check compressed air pressure, requirement: 4 – 7 bar	
	Air tubing	Check correct length and diameter of compressed air supply tubing.	
	Connection of air lines	Check compressed air lines	

Table 5-1

If you need any further information, please contact one of our service centers. You will find the addresses on our website www.vatvalve.com.

6 Maintenance

	<p style="text-align: center;">⚠ WARNING</p> <p>Unqualified personnel Inappropriate handling may cause serious injury or property damage. Only qualified personnel are allowed to carry out the described work.</p>
	<p style="text-align: center;">⚠ WARNING</p> <p>Hazardous components Human body parts may get jammed and severely injured. Before starting maintenance: – disconnect compressed air supply – disconnect electrical power supply</p>
	<p style="text-align: center;">⚠ WARNING</p> <p>Movable parts Human body parts may get jammed and severely injured. Keep human body parts away from movable parts.</p>

6.1 Maintenance intervals

Under clean operating conditions the product does not require any maintenance during specified lifetime.



- Influences from the process may require more frequent maintenance.
- If the door has reached the specified life cycle – see product data sheet – we recommend a general overhaul by VAT. Please contact one of our service centers. You will find the contact data on our website www.vatvalve.com.

6.2 Required tools

- Allen wrench size 3, 4 and 5
- Torque wrench 4.5 Nm / 6 Nm / 9 Nm
- Cleanroom wiper soaked with alcohol (2% methyl ethyl ketone)
- O-Ring removal tool; see «Table 11-1» on page 28

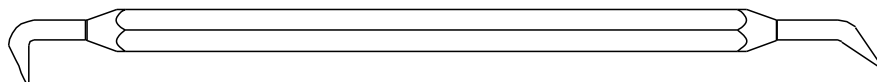





Figure 6-1

6.3 Replacement of actuator pneumatic seals

	<p style="text-align: right;">NOTICE</p> <p>Wrong tightening torque Door body and screws may get damaged. Use tightening torque according to size of the screws.</p>
	<p style="text-align: right;">NOTICE</p> <p>Contamination Product may get contaminated. Always wear cleanroom gloves when handling the product.</p>
	<p style="text-align: right;">NOTICE</p> <p>Inappropriate tools Sealing surfaces may get damaged. Do not use sharp-edged tools.</p>

The item numbers in brackets refer to «Figure 3-1» on page 8.

1. Vent chambers.
2. Open the door.
3. Disconnect compressed air.
4. Disconnect electrical power supply.
5. Remove the 4 set screws (68) on the back of the pressure plate.
6. Remove pressure plate assembly from the actuator shafts, also remove the 2 O-rings (70) from the actuator shafts; place these parts in an area where they are protected from contamination and damage.
7. Remove the screws (99).
8. Remove the actuator assembly from the system.
9. Remove the 4 dowel pins (20) (2 per actuator shaft) and pull the bushing out of the actuator body «Figure 6-2».



Make sure that the bushings do not get damaged during this action.

10. Remove the actuator shafts from the actuator body.

11. Remove seals (10), (11), (12), (14), (15), (18) from their position, see drawing below for details, use O-ring removal tool.
12. Clean and lubricate all grooves for all seals removed in the previous step.
13. Put new seals (10), (11), (12), (14), (15), (18), taken out of the actuator service kit, into the appropriate grooves.
14. Clean and lubricate the pneumatic cylinder walls in the actuator body.
15. Assemble the door in reverse order



Make sure that both O-rings (70) are in the correct position before the pressure plate is mounted on the actuator shafts.

16. Tighten the 3 (Type U) or 4 (Type V) screws (99) with a torque of 6 Nm.

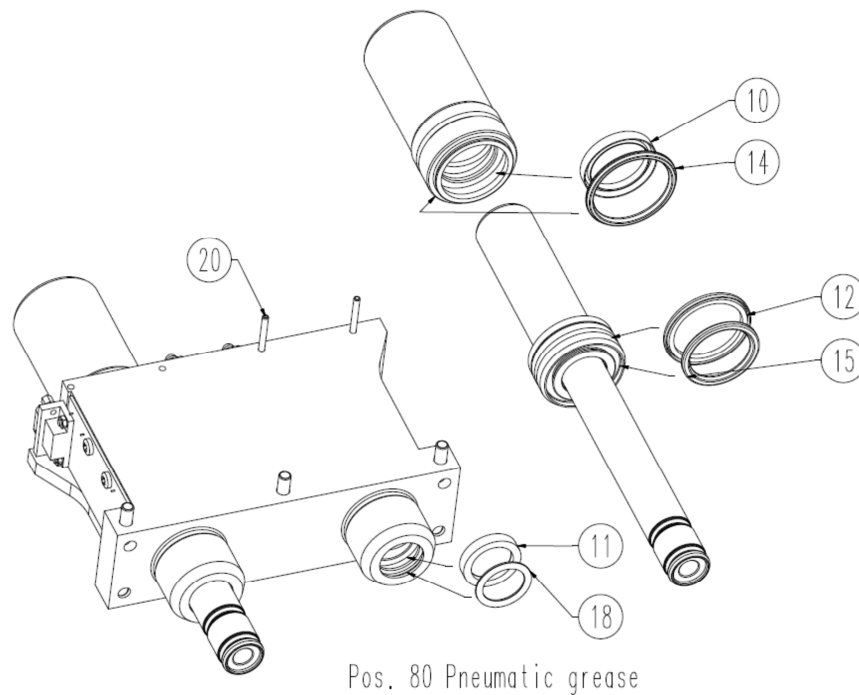

Figure 6-2

17. Connect electrical power supply.
18. Connect compressed air supply.
19. Perform one cycle, see chapter «4.5 Initial operation»

Door is ready for use.

6.4 Replacement of gate

	NOTICE
	<p>Wrong tightening torque</p> <p>Door body and screws may get damaged. Use tightening torque according to size of the screws.</p>

	NOTICE
	<p>Contamination</p> <p>Product may get contaminated. Always wear cleanroom gloves when handling the product.</p>

	NOTICE
	<p>Inappropriate tools</p> <p>Sealing surfaces may get damaged. Do not use sharp-edged tools.</p>

1. Vent chambers.
2. Open the door.
3. Disconnect electrical power supply.
4. Disconnect compressed air supply.
5. Remove the 4 set screws (68); see «Figure 3-1», on the back of the pressure plate.
6. While pulling the pressure plate from the shafts, make sure that the 2 O-rings (70) stay on the shaft or put them back in position right after removing the plate.
7. Remove the 3 screws (75) and washers (61); see «Figure 6-3», and remove gate.



Never use the old, used screws (75) again. If a screw is removed, it has to be replaced by a new one with fresh adhesive coating; otherwise no safe lock is guaranteed.

8. Clean or replace gate.
9. Use only the new screws (75) supplied with the spare gate or ordered separately to reassemble the gate.
10. Before reassembling the gate to the pressure plate, make sure that all the pistons and washers are at the correct position according to the assembly drawing.
11. Tighten the 3 screws (75) with a torque of 9 Nm; see «Figure 6-3».

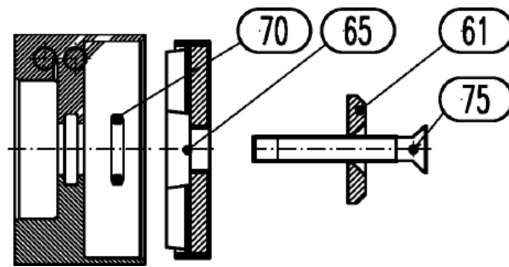

Figure 6-3

- 61 Washer
- 65 Piston
- 70 O-Ring
- 75 Screw

12. Before mounting the pressure plate back onto the shafts, make sure that the 2 O-rings (70) are in the correct position.
13. Tighten the 4 set screws (68) with a torque of 4.5 Nm; These 4 screws have to be tightened step by step, cross-wise to evenly distribute force on the pressure bar. Make sure that the tips of the set screws fit into the 90° countersunk in the shafts.



During system maintenance it is advised to check if the 3 screws (75) are still tightened properly according point 11.

14. Connect electrical power supply of position indicator.
15. Connect compressed air supply.
16. Perform one cycle, see chapter «4.5 Initial operation».





Door is ready for use.

7 Repairs

Repairs may only be carried out by the VAT service staff. In exceptional cases, the customer is allowed to carry out the repairs, but only with the prior consent of VAT.

Please contact one of our service centers. You will find the addresses on our website www.vatvalve.com.

8 Dismounting and Storage

	<p style="text-align: center;">⚠ WARNING</p> <p>Unqualified personnel Inappropriate handling may cause serious injury or property damage. Only qualified personnel are allowed to carry out the described work.</p>
	<p style="text-align: center;">⚠ WARNING</p> <p>Hazardous components Human body parts may get jammed and severely injured. Before dismantling the product: – disconnect compressed air supply – disconnect electrical power supply</p>
	<p style="text-align: center;">⚠ WARNING</p> <p>Movable parts Human body parts may get jammed and severely injured. Keep human body parts away from movable parts.</p>
	<p style="text-align: center;">NOTICE</p> <p>Contamination Product may get contaminated. Always wear cleanroom gloves when handling the product.</p>

8.1 Dismounting

	NOTICE
	<p>Sensitive product</p> <p>Product will get damaged if not handled carefully.</p> <p>Handle product with care: Do not touch solid objects when lifting the product and place it down slowly and gently.</p>

1. Open the door.
2. For dismounting the door follow the steps of chapter «4 Installation», however in reverse order.
Pay attention to the safety instructions!

8.2 Storage

	NOTICE
	<p>Wrong storage</p> <p>Inappropriate temperatures and humidity may cause damage to the product.</p> <p>Door must be stored at:</p> <ul style="list-style-type: none"> – relative humidity between 10% and 70% – temperature between +10 °C and +50 °C – non-condensing environment

	NOTICE
	<p>Inappropriate packaging</p> <p>Product may get damaged if inappropriate packaging material is used.</p> <p>Always use the original packaging material and handle product with care.</p>

1. Clean / decontaminate product.
2. Cover the gate plate with protective foil.
3. Pack product appropriately by using the original packaging material.

9 Packaging and Transport

	⚠ WARNING
	Unqualified personnel Inappropriate handling may cause serious injury or property damage. Only qualified personnel are allowed to carry out the described work.

	⚠ WARNING
	Harmful substances Risk of injury in case of contact with harmful substances. Remove harmful substances (e. g. toxic, caustic or microbiological ones) from valve before you return the valve to VAT.

	NOTICE
	Inappropriate packaging Product may get damaged if inappropriate packaging material is used. Always use the original packaging material and handle product with care.



- When returning products to VAT, please fill out the VAT form «Declaration of Chemical Contamination» and send it to VAT in advance. The form can be downloaded from our website www.vatvalve.com.
- If products are radioactively contaminated, the VAT form «Contamination and Radiation Report» must be filled out. Please contact VAT in advance.
- If products are sent to VAT in contaminated condition, VAT will carry out the decontamination procedure at the customer's expense.

9.1 Packaging

1. Cover the gate with protective foil.
2. Pack product appropriately by using the original packaging material.



VAT disclaims any liability for damages resulting from inappropriate packaging.

9.2 Transport



NOTICE



Inappropriate packaging

Product may get damaged if inappropriate packaging material is used.
Always use the original packaging material and handle product with care.



VAT disclaims any liability for damages resulting from inappropriate packaging.

10 Disposal

	 WARNING	
	Harmful substances Environmental pollution. Discard products and parts according to the local regulations.	

11 Spare parts

	NOTICE
<p>Non-original spare parts Non-original spare parts may cause damage to the product. Use original spare parts from VAT only.</p>	



- Please specify the fabrication number of the product when you place an order for spare parts; see chapter «1.1 Identification of product». This is to ensure that the appropriate spare parts are supplied.
- VAT makes a difference between spare parts that may be replaced by the customer and those that need to be replaced by the VAT service staff.
- «Table 11-1» only contains spare parts that may be replaced by the customer. If you need any other spare parts, please contact one of our service centers. You will find the addresses on our website www.vatvalve.com.

Description	Part No.	Quantity per valve	Maintenance procedure see chapter
Gate with O-ring groove	on request	1	«6.4 Replacement of gate»
O-ring for gate	on request	1	«6.4 Replacement of gate»
Vulcanized gate	on request	1	«6.4 Replacement of gate»
Revision kit actuator	556366	1	«6.3 Replacement of actuator pneumatic seals»
Lubricant	N-6951-403	1	«6.3 Replacement of actuator pneumatic seals»
O-ring removal tool	234859	1	–

Table 11-1

